

JMS Series Slant Plate Clarifier

The 8 step process a slant plate clarifier goes through to treat wastewater:

1. Influent water enters the clarifier through the feed chamber.
2. The water enters the inclined plates through the feed slots.
3. The liquid is forced up through the plates in a counter-current flow pattern.
4. The clarified flow rises between the plates while gravity forces the solids to fall out of the flow.
5. The solids settle in the cone section of the clarifier for removal.
6. Clarified liquid flows up over the weirs and into a trough.
7. The clarified effluent is discharged from a connection at the bottom of the trough.
8. The sludge is drawn off the bottom of the sludge chamber and flows to the sludge thickener for further dewatering.

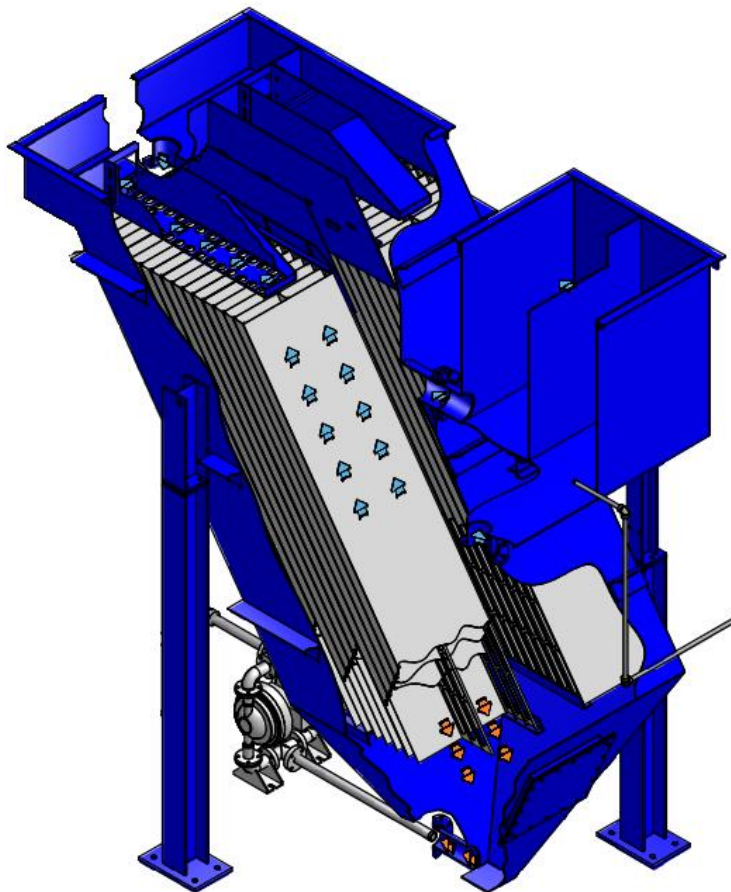

Features

- Fully Integrated skid mounted system.
- Space-saving design that takes up around 2/3 of the floor space a non-inclined clarifier requires.
- Large settling surface areas.
- Tnemec interior/exterior coating systems prevents corrosion and paint chipping.
- Fiberglass plate pack allows for better solids settling.
- Shipped ready for install and start-up with minimal labor and minimal maintenance.
- Stainless overflow components and hardware.
- No moving parts in settling area.
- Made in the USA.

With JMark's industry leading-quality products, you'll reduce hazardous waste, save water, and save money. Over our 40+ years of business and expertise, we have refined our process down to a science.

Each J Mark Slant Plate Clarifier can be equipped with a flash mixing and flocculation tank upstream of the inlet pipe.

We only use top-quality fiberglass plate packs that are specifically designed for maximum solids separation and submersion in the chemical resistant clarifier tanks.

Our slant plate clarifiers are ideal for large bodies of wastewater that need treatment, as they work quickly and effectively with minimal cost and monitoring.

Contact J Mark Systems to purchase or rent a fully integrated system that meets your specifications.

Call: (616)784-6005

Email: sales@jmarksystems.com

SPECS

- Clarifier Sizes = 25, 50, 70, 100, 120, 150 gpm
- Design suspended solid removal = 600 milligrams per liter influent
- Liquid solids settling rate = 12 ft. per hour

